

INSTRUCTION MANUAL



KEPCO An ISO 9001 Company.

**KIT
DIN ERD
-60S**

DIN-RAIL MOUNTING KIT FOR SERIES ERD 60W

DESCRIPTION. Kepco KIT, Model DIN ERD-60S, contains two preassembled mounting clips and associated hardware used to install ERD 60 Watt Series power supplies on a DIN rail. The "S" suffix is for mounting along the short dimension (width) as shown in Figure 1. Outline dimensions are shown in Figure 4.

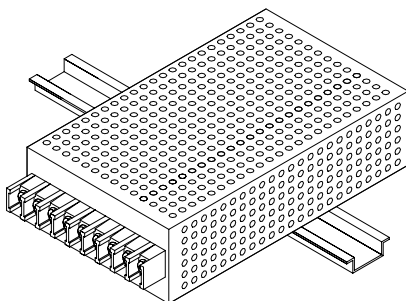

3042028

FIGURE 1. S SUFFIX ORIENTATION

INSTALLING KIT. Attach the preassembled mounting clips to the power supply using the hardware supplied (see Figure 3). The clips may be mounted with the release lever on either side to facilitate removal.

INSTALLING POWER SUPPLY ON DIN RAIL. To mount the power supply on the rail insert one end of both clips under one edge of the rail, then snap the other end of the two clips into place (see Figure 2A).

REMOVING POWER SUPPLY FROM DIN RAIL. While grasping the power supply with one hand, use a screwdriver to apply leverage towards the left as shown in Figure 2B to disengage each clip from the rail. Where mounting clips are close together, it may be necessary to apply leverage with two screwdrivers simultaneously.

A - INSTALLATION

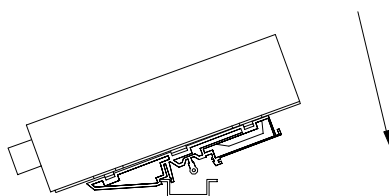

3042031

B - REMOVAL

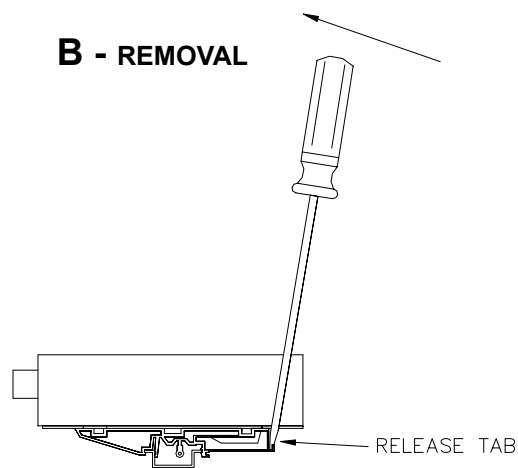
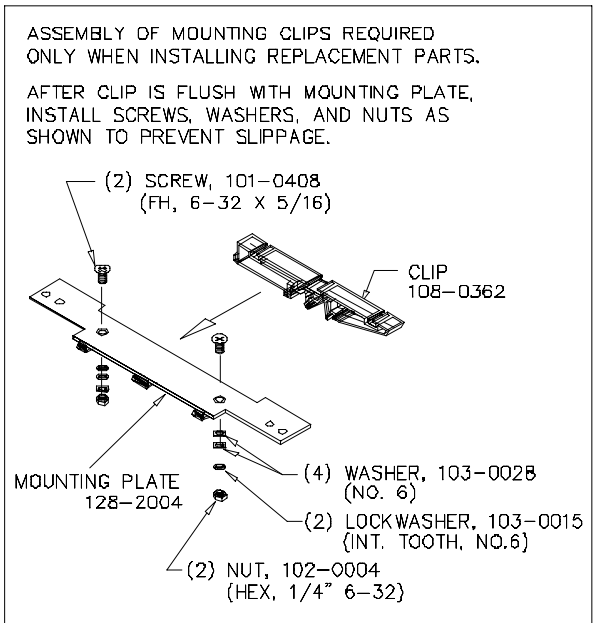

FIGURE 2. INSTALLATION AND REMOVAL OF POWER SUPPLY FROM DIN RAIL

KEPCO, INC. ● 131-38 SANFORD AVENUE ● FLUSHING, NY. 11352 U.S.A. ● TEL (718) 461-7000 ● FAX (718) 767-1102

<http://www.kepcopower.com> ● email: hq@kepcopower.com



3042029

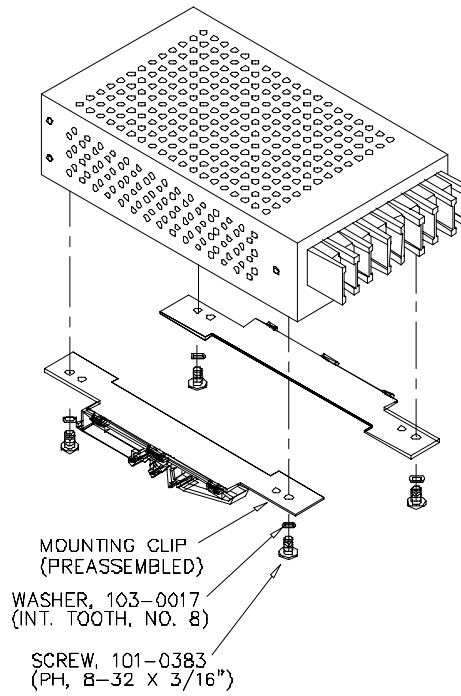

FIGURE 3. INSTALLATION OF KIT ON ERD 60W POWER SUPPLY

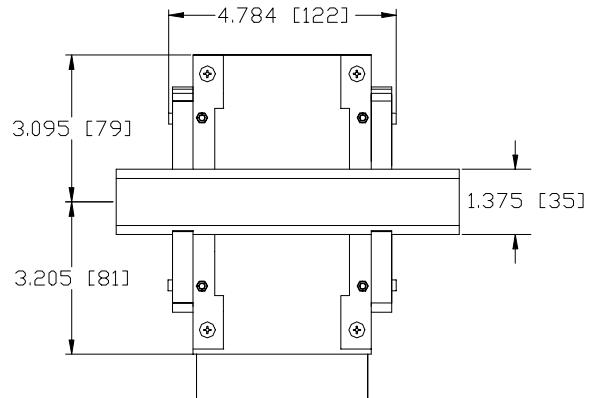
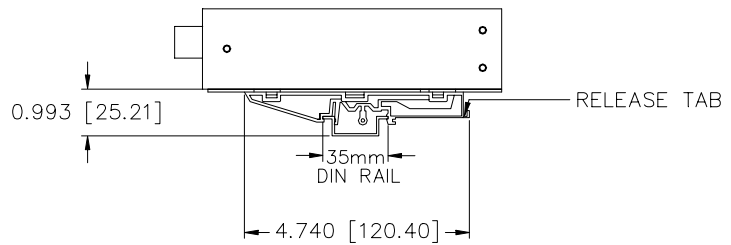
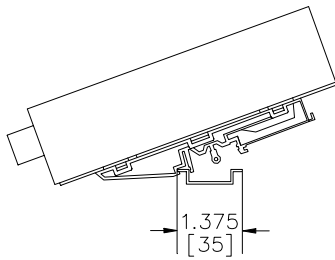

FIGURE 4. ERD 60W POWER SUPPLY WITH KIT INSTALLED, OUTLINE DIMENSIONS

NOTE:
UNLESS OTHERWISE SPECIFIED, DIMENSIONS
ARE IN INCHES, DIMENSIONS IN BRACKETS ARE
IN MILLIMETERS.

3042030